

4DWD- 110

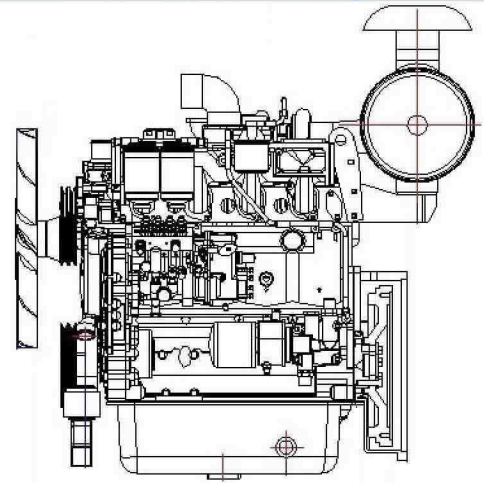

POWER RATING

Engine Speed	Type of Operation	Engine Gross Power	
		kW	PS
1500 rpm	Prime Power	82	110
	Standby Power	88	120
1800 rpm	Prime Power	86	117
	Standby Power	92	125

- The engine performance is as per ISO 3046. Type of operation is based on ISO 8528.
- Prime power is available for an unlimited number of hours per year in a variable load application.
- The permissible average power output over 24 hours of operation shall not exceed 80% of the prime power rating.

Engine Specifications

- Engine Type In-Line type, 4 strokes, water-cooled Turbocharged air-to-air intercooled
- Combustion type Direct injection
- Cylinder Type Wet liner
- No. of Cylinders 4
- Bore × stroke 110 × 125 mm
- Displacement 4.75 liter
- Compression ratio 16 : 1
- Firing order 1 – 3 – 4 – 2
- Injection timing 15 °BTDC
- Dry weight Approx. 500 kg
- Dimension(LxWxH) 1113 × 720 × 1128 mm
- Rotation Anti-clockwise (Face to the flywheel)
- Fly wheel housing SAE NO. 3
- Fly wheel SAE NO.11.5
- Ring Gear Tooth 130 EA

Mechanism

- Type Overhead valve
- Number of valve Intake 1, exhaust 1 per Cylinder
- Valve lashes at cold Intake. 0.3 mm
Exhaust 0.5 mm

Fuel Consumption Data

Speed	(Liter/ Hour)			
	1500 rpm		1800 rpm	
Rating	Prime	Standby	Prime	Standby
	82 kW	88 kW	86 kW	92 kW
100% Load	23.2	24.6	24.8	24.0
75% Load	17.5	18.2	18.7	19.5
50% Load	12.9	13.3	13.7	14.3
25% Load	8.2	8.5	8.7	9.1

Fuel System

- Injection pump Direct Injection type
- Governor Electronic type
- Feed pump Mechanical type
- Injection nozzle Multi-hole type
- Opening pressure 250 kg/cm² (3556 psi)
- Fuel filter Full Flow, Cartridge type
- Used fuel Diesel fuel oil

Lubrication System

- Lub. Oil Grade CF-4 oil
- Lub. Oil Pan Capacity 14 liter
- Max. allowable Oil Temp 120 degree C.
- Oil pressure Min. 294 kPa
Max. 490 kPa
- Oil Consumption Rate ≤ 1.2 g/kWh

Cooling System

- Cooling method Fresh water forced type
- Water Pump Centrifugal, Belt driven
- Water capacity 10 liter (engine only)
- Max. Water Temp 99 degree C.
- Thermostat Open 76°C / Full 90°C
- Water in/outlet Dia 45 mm
- Cooling method Fresh water forced type
- Cooling Fan Blade 10EA - Ø 530 mm

Engineering Data

		1500 rpm		1800 rpm	
		Prime	S/B	Prime	S/B
○ Media Flow					
Combustion Air	m3/min	7.0	7.3	7.0	7.4
Exhaust Gas	m3/min	17.3	18.4	17.5	18.6
Cooling Fan	m3/min				
○ Heat Rejection					
to Exhaust	kW	67	71	69	74.5
to Coolant	kW	43	46	44	48
to Intercooler	kW	8	9	9	12
to radiation	kW	7	8	7	8

Electric System

- Charging generator 28V × 36A (1008 W)
- Voltage regulator Build-in type IC regulator
- Starting motor 24V × 7.5 kW
- Battery Voltage 24 V
- Battery Capacity 120 AH

Conversion Table

in. = mm × 0.0394	lb/ft = N.m × 0.737
PS = kW × 1.3596	U.S. gal = lit. × 0.264
psi = kg/cm ² × 14.2233	kW = 0.2388 kcal/sec
in ³ = lit. × 61.02	lb/PS.h = g/kW.h × 0.00162
HP= PS × 0.98635	Cfm = m3/min × 35.336
lb = kg × 2.20462	

Engine Layout & Dimension

